

# Standard PALOMAR side view measurements

## With 3 available picket options

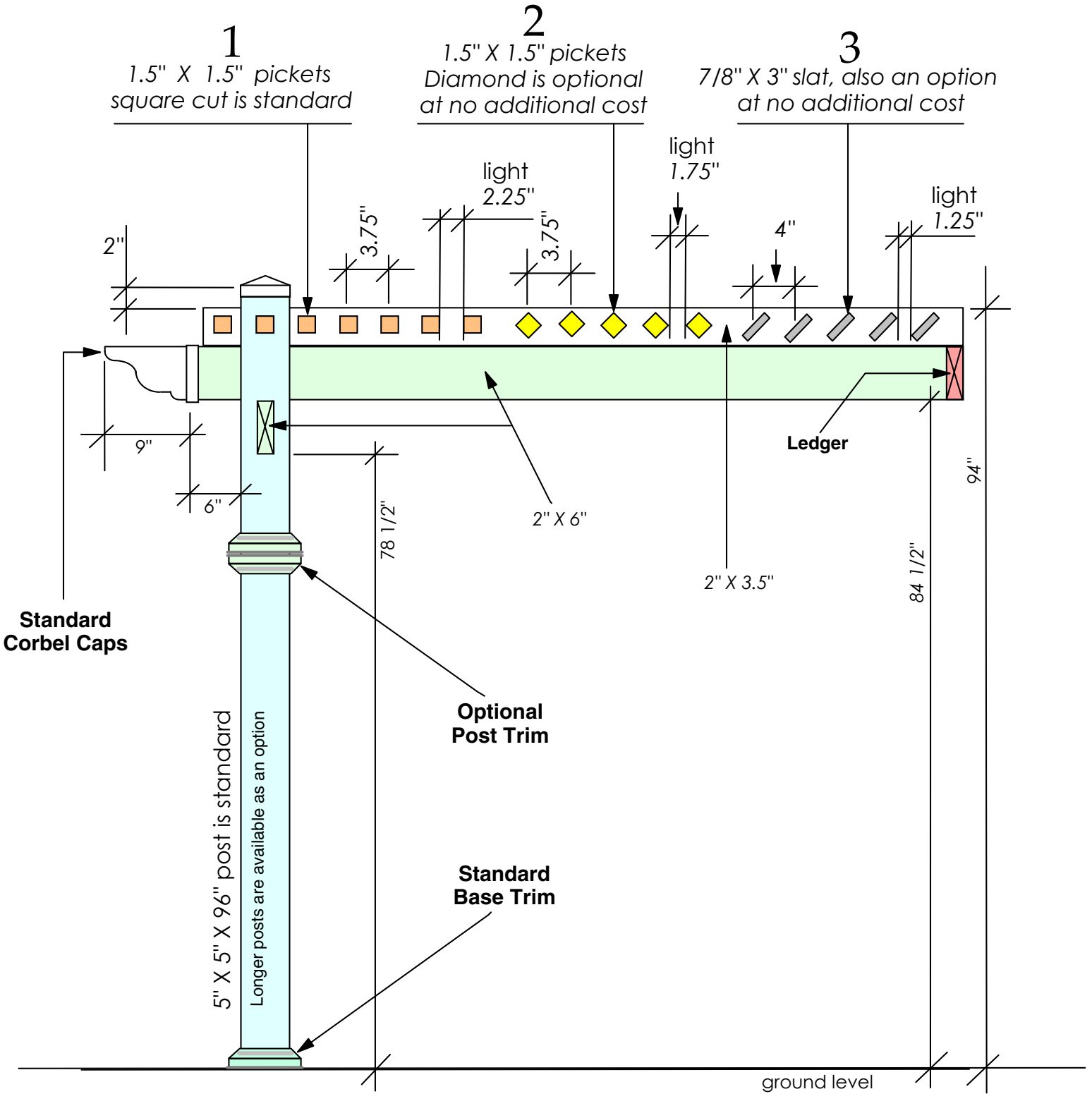

All the information on this sheet, drawings or copy, are the confidential, copyright Property of Finyl Vinyl Inc. Huntington Beach CA, Greensboro NC.



N.T.S.  
7/07

TYPICAL PATIO COVER ATTACHMENT METHODS

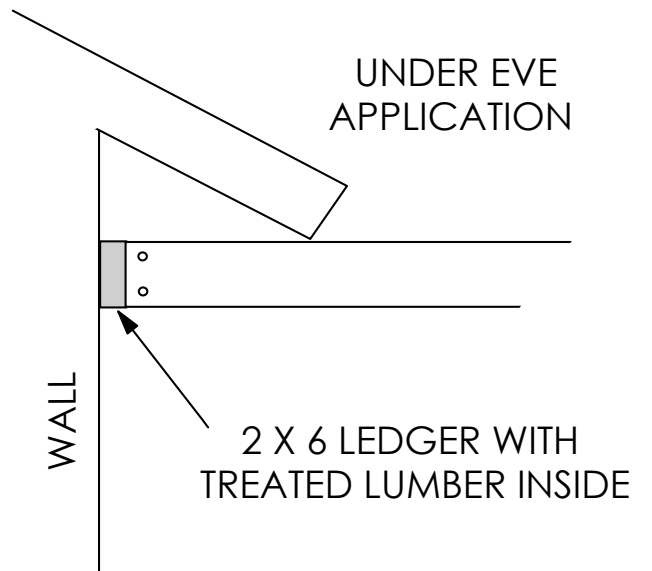
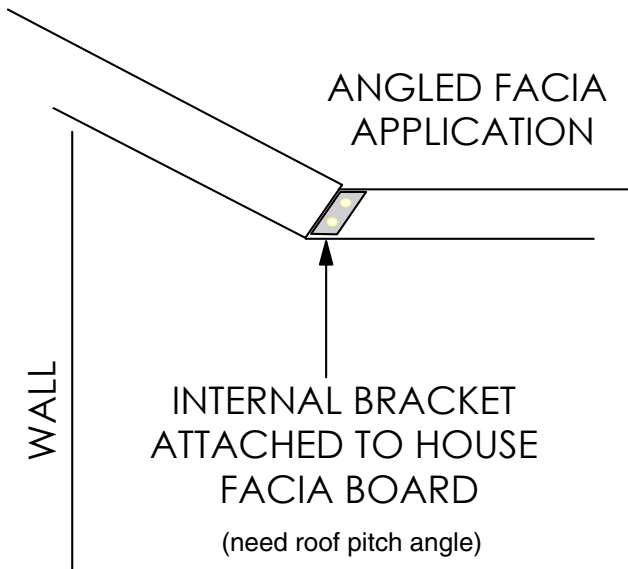
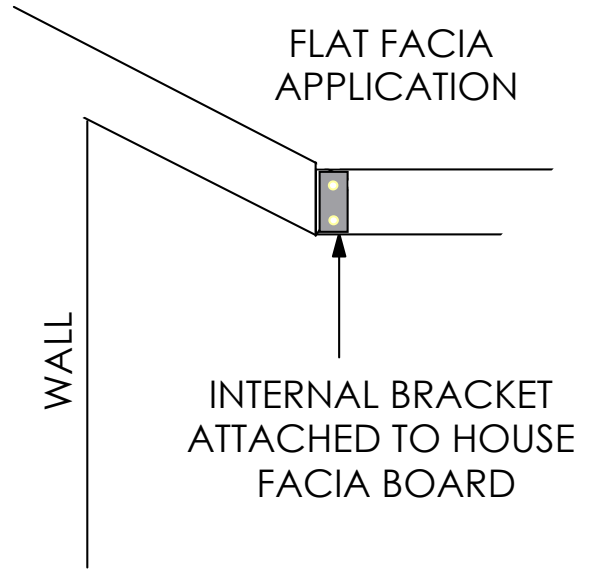
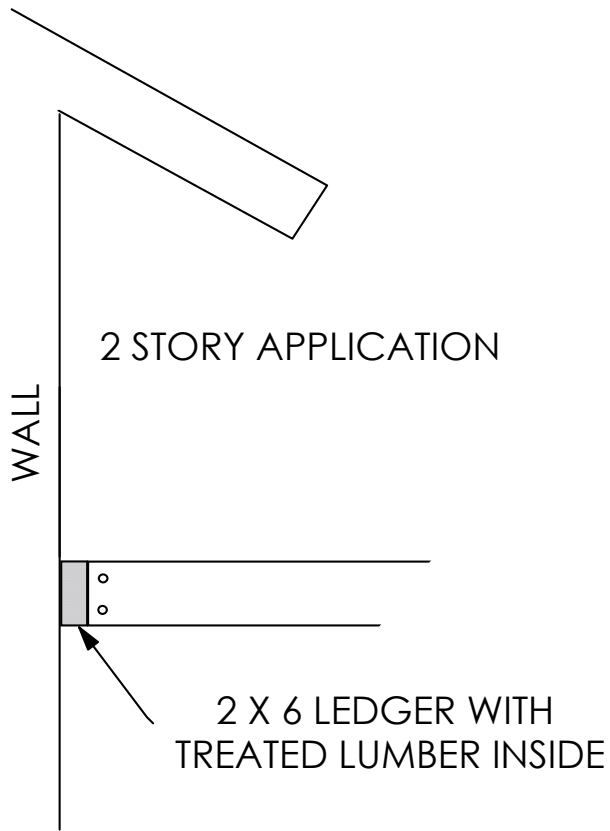

# Typical LEDGER MOUNTING side view

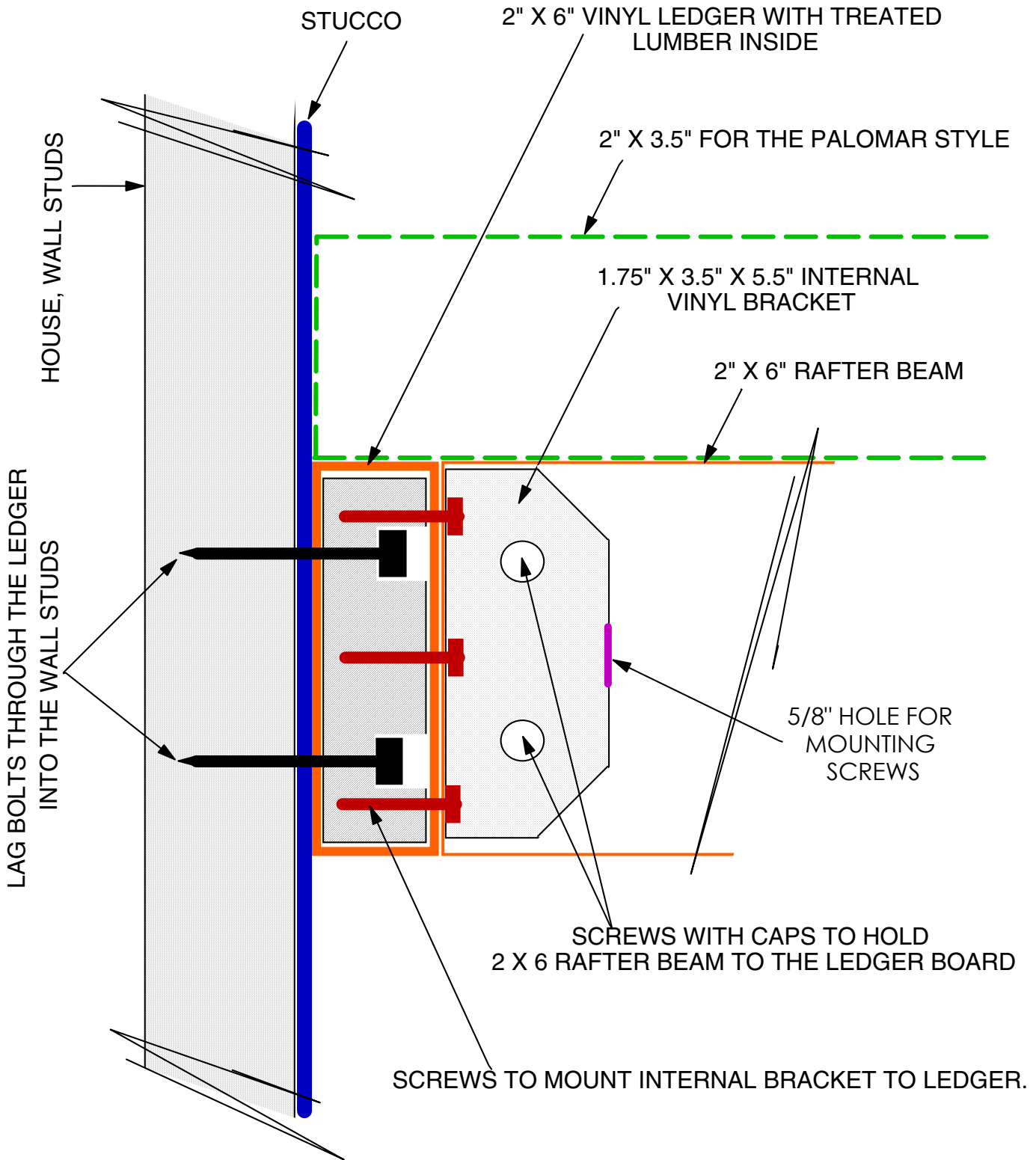

All the information on this sheet, drawings or copy, are the confidential, copyright Property of Finyl Vinyl Inc. Huntington Beach CA, Greensboro NC.



N.T.S.  
8/07

# REBAR & CEMENT SUGGESTED POST INSTALLATION

TOP VIEW OF POST

48" SECTIONS  
OF REBAR

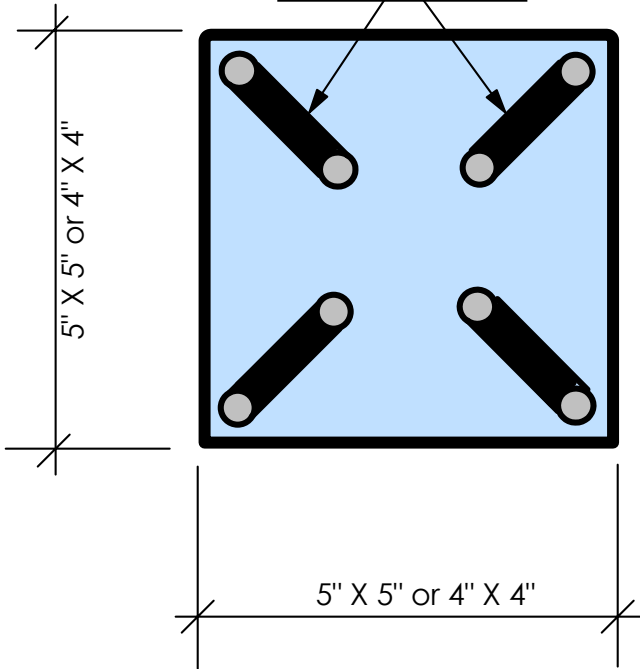

SIDE VIEW OF POST

1/2" x 48" SECTION  
OF REBAR

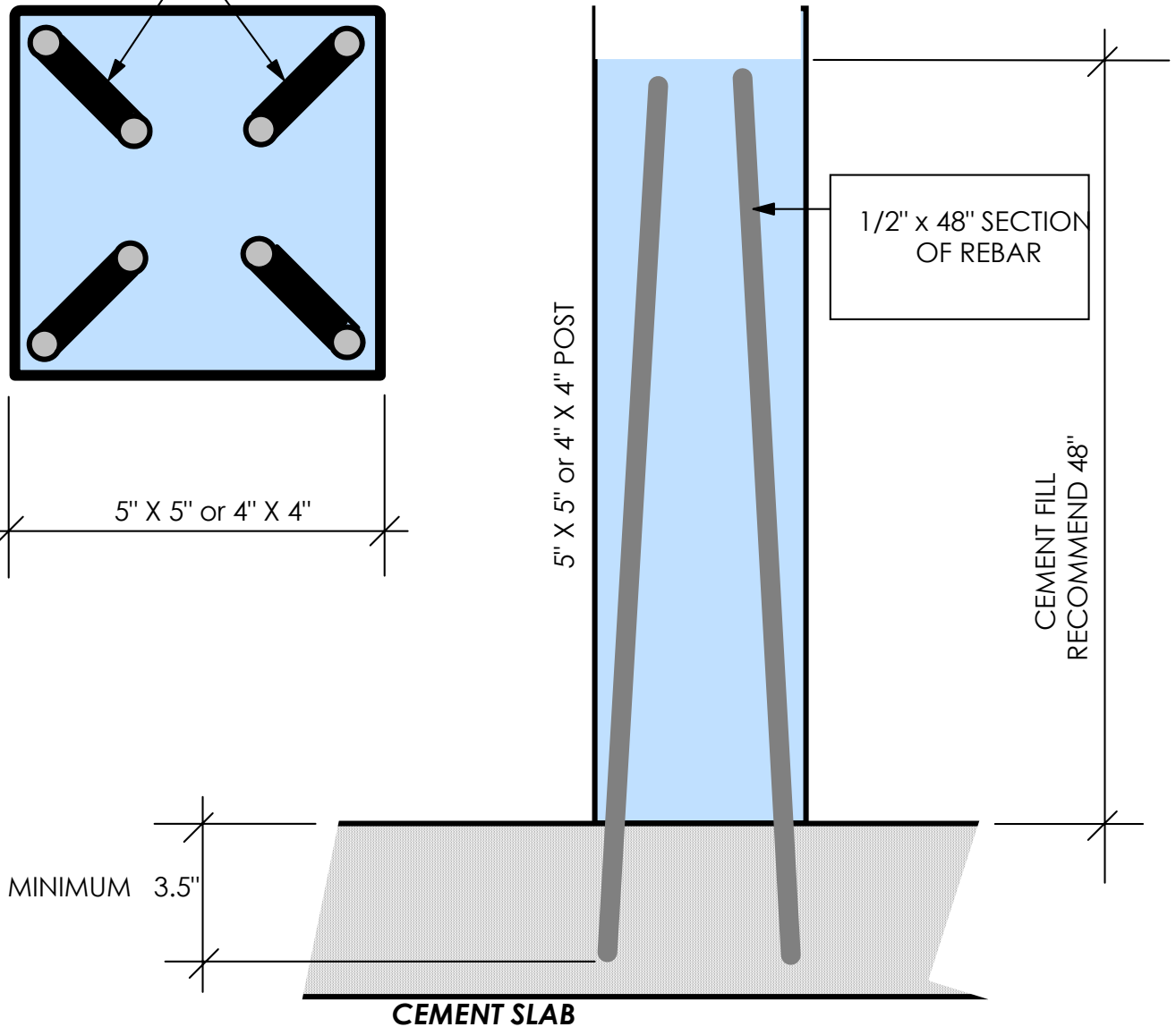

All the information on this sheet, drawings or copy, are the confidential,  
copyright Property of Finyl Vinyl Inc. Huntington Beach CA, Greensboro NC.



N.T.S.  
5 / 06